



<https://www.gptcthirurangadi.in>

LAB MANUAL

ANALOG COMMUNICATION LAB



STATE INSTITUTE OF TECHNICAL TEACHERS TRAINING AND RESEARCH

GENERAL INSTRUCTIONS

Rough record and Fair record are needed to record the experiments conducted in the laboratory. Rough records are needed to be certified immediately on completion of the experiment. Fair records are due at the beginning of the next lab period. Fair records must be submitted as neat, legible, and complete.

INSTRUCTIONS TO STUDENTS FOR WRITING THE FAIR RECORD

In the fair record, the index page should be filled properly by writing the corresponding experiment number, experiment name, date on which it was done and the page number.

On the **right side** page of the record following has to be written:

1. **Title:** The title of the experiment should be written in the page in capital letters.
2. In the left top margin, experiment number and date should be written.
3. **Aim:** The purpose of the experiment should be written clearly.
4. **Apparatus/Tools/Equipments/Components used:** A list of the Apparatus/Tools/ Equipments /Components used for doing the experiment should be entered.
5. **Principle:** Simple working of the circuit/experimental set up/algorithm should be written.
6. **Procedure:** steps for doing the experiment and recording the readings should be briefly described(flow chart/programs in the case of computer/processor related experiments)
7. **Results:** The results of the experiment must be summarized in writing and should be fulfilling the aim.
8. **Inference:** Inference from the results is to be mentioned.

On the **Left side** page of the record following has to be recorded:

1. **Circuit/Program:** Neatly drawn circuit diagrams/experimental set up.
2. **Design:** The design of the circuit/experimental set up for selecting the components should be clearly shown if necessary.



3. Observations:

- i) Data should be clearly recorded using Tabular Columns.
- ii) Unit of the observed data should be clearly mentioned
- iii) Relevant calculations should be shown. If repetitive calculations are needed, only show a sample calculation and summarize the others in a table.

4. **Graphs:** Graphs can be used to present data in a form that shows the results obtained, as one or more of the parameters are varied. A graph has the advantage of presenting large amounts of data in a concise visual form. Graphs should be in a square format.

GENERAL RULES FOR PERSONAL SAFETY

1. Always wear tight shirt/lab coat, pants and shoes inside workshops.
2. REMOVE ALL METAL JEWELLERY since rings, wrist watches or bands, necklaces, etc. make excellent electrodes in the event of accidental contact with electric power sources.
3. DO NOT MAKE CIRCUIT CHANGES without turning off the power.
4. Make sure that equipment working on electrical power are grounded properly.
5. Avoid standing on metal surfaces or wet concrete. Keep your shoes dry.
6. Never handle electrical equipment with wet skin.
7. Hot soldering irons should be rested in its holder. Never leave a hot iron unattended.
8. Avoid use of loose clothing and hair near machines and avoid running around inside lab.

TO PROTECT EQUIPMENT AND MINIMIZE MAINTENANCE:

DO: 1. SET MULTIRANGE METERS to highest range before connecting to an unknown source.

2. INFORM YOUR INSTRUCTOR about faulty equipment so that it can be sent for repair.

DO NOT: 1. Do not MOVE EQUIPMENT around the room except under the supervision of an instructor.



CIRCUIT DIAGRAMS

LOW PASS FILTER (PASSIVE)

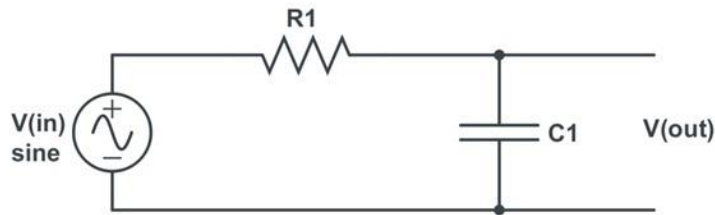

$$f_c = \frac{1}{2\pi RC}$$

Let $f_c = 1\text{KHz}$

$R1 = 1.6\text{K}$, $C1 = 0.1\mu\text{F}$

LOW PASS FILTER (ACTIVE)

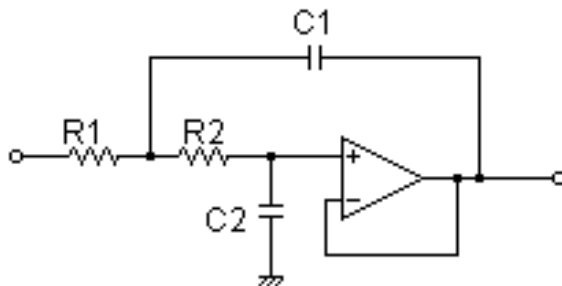

$$f_c = \frac{1}{2\pi\sqrt{R1C1R2C2}}$$

IC=741, $R1 = 30\text{K}$, $R2 = 18\text{K}$, $C1 = 0.01\mu\text{F}$, $C2 = 0.0047\mu\text{F}$

EXPERIMENT No: 1

FILTERS LPF, HPF AND BPF



AIM

To set up Low pass filter (LPF), High Pass filter (HPF) and Band Pass Filter (BPF) to find out the cut off frequency.

OBJECTIVES

To study about different types of passive filters and active filters, plot the frequency response and find out the cut off frequency .

EQUIPMENTS/COMPONENTS

Sl.No	Name & Specification.	Quantity required.
1	CRO/DSO	1No.
2	Function generator	1No.
3	Dual Power supply +/- 15V	1No.
4	OP-AMP (741)	1 No
5	Capacitors-100nF,01 μ F,10nF,560pF	1 each.
6	Resistors- 1k Ω ,10k Ω , 560 Ω	2,1,1 Nos.

PRINCIPLE

Filter is a circuit that can be designed to modify, reshape or reject all unwanted frequencies of an electrical signal and accept or pass only wanted signals. Passive Filters are made up of passive components such as resistors, capacitors and inductors and have no amplifying elements (transistors, op-amps, etc) so have no signal gain, therefore their output level is always less than the input.

Filters are so named according to the frequency range of signals that they allow to pass through them, while blocking or attenuating the rest. The most commonly used filter designs are

1. The Low Pass Filter (LPF)

The low pass filter only allows low frequency signals from 0Hz to its cut-off frequency, f_c point to pass while blocking those any higher. Cut off frequency $f_c = \frac{1}{2\pi RC}$.

2. The High Pass Filter (HPF)

The high pass filter only allows high frequency signals from its cut-off frequency, f_c and block lower frequencies. Cut off frequency $f_c = \frac{1}{2\pi RC}$.

3. The Band Pass Filter (BPF).

The band pass filter allows signals falling within a certain frequency band while blocking both the lower and higher frequencies on either side of this frequency band.

PROCEDURE

1. Check all the components, equipments and signal probes
2. Set up the connections as per the circuit diagram
3. a) For LPF (Passive & Active)

Apply 1V pp/100Hz sine wave to the circuit

Observe the output waveform in the CRO, and measure amplitude

HIGH PASS FILTER (PASSIVE)

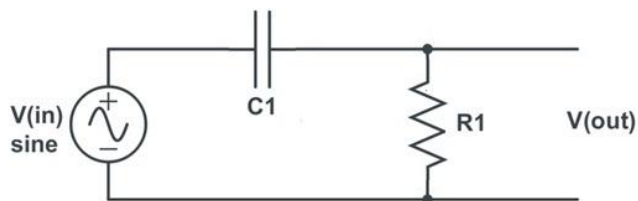

$$f_c = \frac{1}{2\pi RC}$$

Let $f_c = 1\text{KHz}$

$R1 = 1.6\text{K}$, $C1 = 0.1\mu\text{F}$

HIGH PASS FILTER (ACTIVE)

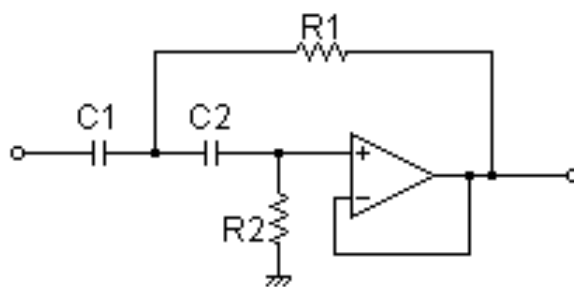

$$f_c = \frac{1}{2\pi\sqrt{R1C1R2C2}}$$

IC=741, $R1 = 11\text{k}\Omega$, $R2 = 22\text{k}\Omega$, $C1 = 0.01\mu\text{F}$, $C2 = 0.01\mu\text{F}$

BAND PASS FILTER (PASSIVE)

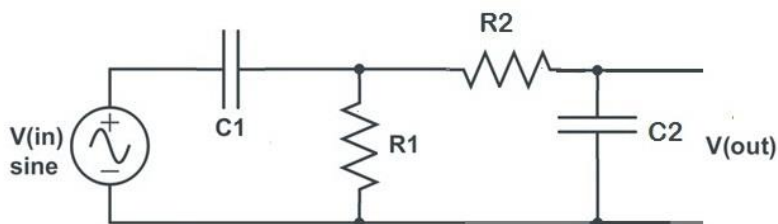

$R1 = 1.5\text{K}$, $R2 = 560\Omega$, $C1 = 0.1\mu\text{F}$, $C2 = 0.1\mu\text{F}$

Vary the frequency of input signal up to 5kHz with a uniform increment of 200 Hz.



Plot the frequency response curve.

b) For HPF (Passive & Active)

Apply 1V pp/1kHz sine wave to circuit.

Observe the output waveform in the CRO and measure amplitude.

Vary the frequency of input signal up to 10 kHz with uniform increment of 200Hz.

Plot the frequency response curve.

c) For BPF (Passive & Active)

Apply 1V pp/100Hz sine wave to circuit.

Observe the output waveform in the CRO and measure amplitude.

Vary the frequency of input signal up to 5 kHz with uniform increment of 200Hz.

Plot the frequency response curve.

RESULT

INFERENCE



BAND PASS FILTER (ACTIVE)

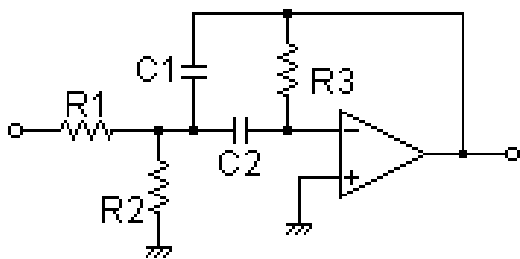

IC= 741, R1 = 4.7k Ω , R2 = 4.7k Ω , R3 = 5.6k Ω , C1 = 0.0047 μ F, C2 = 0.01 μ F

OBSERVATIONS

Vin=1 V pp

Sl. No	Frequency (Hz)	V out(v)	Gain (Vout/Vin)	Gain in dB 20 log(Vout/Vin)

GRAPH



<https://www.gptcthirurangadi.in>

CIRCUIT DIAGRAM

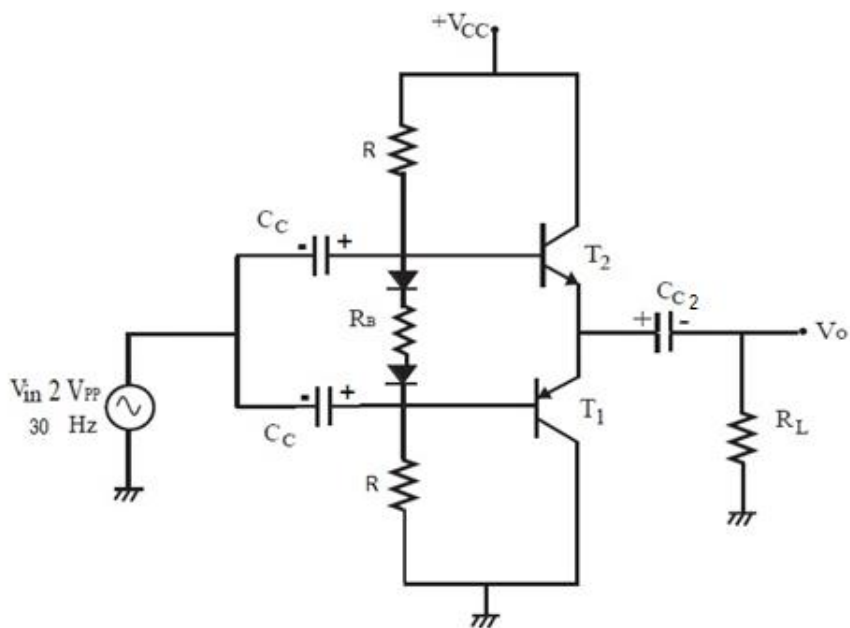

$R=1K\Omega$, $R_B=1K\Omega$, $R_L=1K\Omega$, $C_{C1}=220\mu F$, $C_{C2}=100\mu F$, $D_1\&D_2=1N4001$,
 $T_1=SK100$, $T_2=SL100$ & $V_{cc}=10V$

Alternate Circuit diagram.

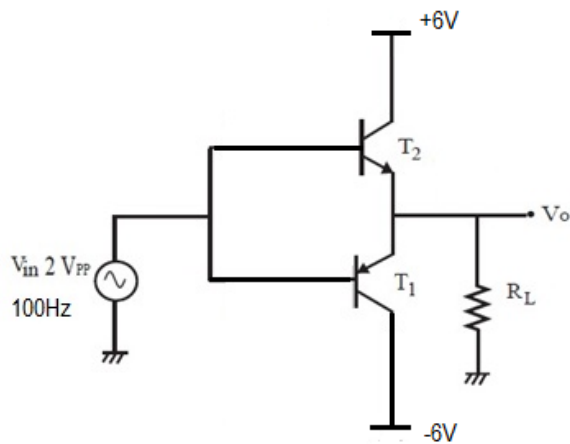

$T_1=SK100$, $T_2=SL100$, $R_L=1K\Omega$

GRAPH

EXPERIMENT No: 2



AUDIO POWER AMPLIFIER

AIM

To set up Audio power amplifier.

OBJECTIVES

To study about Class AB power amplifier.

EQUIPMENTS/COMPONENTS

Sl.No	Name& Specifications	Quantity required
1	CRO/DSO	1 No
2	Function Generator 20MHz	1No
3	Regulated DC Power supply 0-9V	1No
4	Transistors (SL100,SK100)	1 Each
5	Diode 1N 4001	2 Nos
6	Capacitor 220 μ F	3Nos
7	Resistors 1K	4 Nos

PRINCIPLE

An Audio power amplifier is an amplifier that amplifies low power audio signals (frequencies between 20-20000 Hz) to a level suitable for driving loudspeakers. It is the final electronic stage in a typical audio playback chain. The term power amplifier is a relative term with respect to the amount of power delivered to the load and provided by the power supply circuit. Power amplifier circuits (output stages) are classified as A, B, AB and C for analogue designs and class D and E for switching designs based on the proportion of each input cycle (conduction angle), during which an amplifying device passes current.

Class A

100% of the input signal is used (conduction angle $\theta = 360^\circ$). The active element remains conducting all of the time.

Class B

50% of the input signal is used ($\theta = 180^\circ$); the active element carries current half of each cycle, and is turned off for the other half.

Class AB

Class AB is intermediate between class A and B, the two active elements conduct more than half of the time

Class C

Less than 50% of the input signal is used (conduction angle $\theta < 180^\circ$).



<https://www.gptcthirurangadi.in>

Class D



A Class D amplifier uses some form of pulse-width modulation to control the output devices.

PROCEDURE

- 1 Check all the components and signal probes
- 2 Set up the circuit as per the diagram
- 3 Check DC level conditions
- 4 Apply 2Vpp/30Hz sine wave and observe output waveform
- 5 Draw the input and output waveform

RESULT

INFERENCE

CIRCUIT DIAGRAM

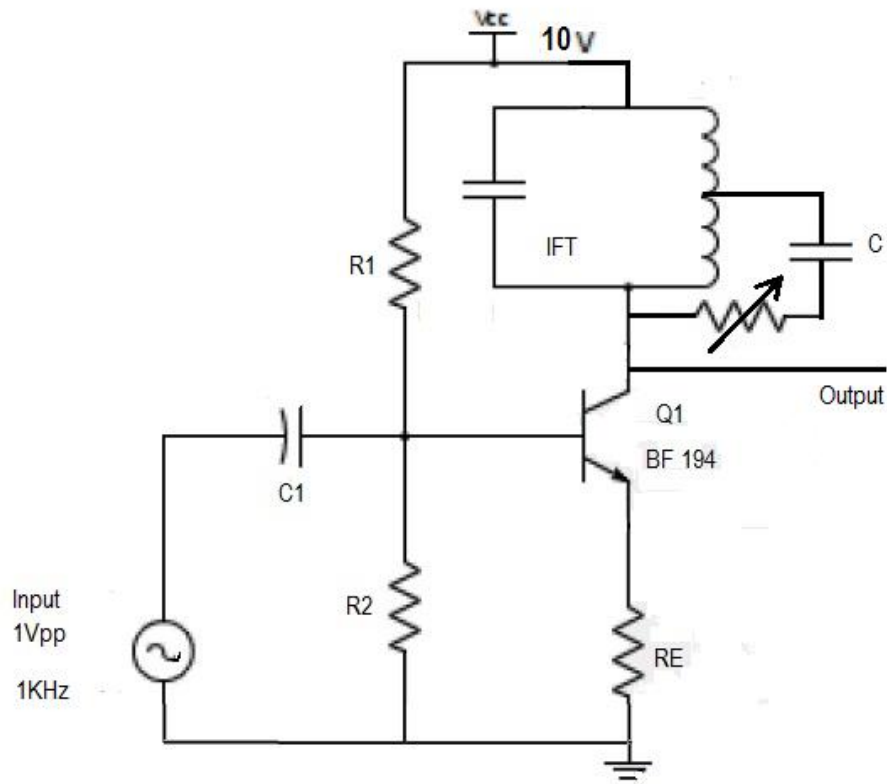

$R_1=82K$, $R_2=18K$, $R_e=1K$, $Pot=47K$, $C_1=0.1\mu F$, $C=330pf$

OBSERVATION

Sl.No	Am(volts)	V_{max}	V_{min}	m	%m

GRAPH

EXPERIMENT No:3



AM GENERATOR USING TRANSISTOR

AIM

To set up AM generator using transistor.

OBJECTIVES

To study the generation of Amplitude Modulated wave.

EQUIPMENTS/COMPONENTS

Sl. No	Name & Specification	Quantity required
1	CRO/DSO	1 No
2	Function Generator	1 No
3	Regulated DC Power supply 0-12v	1No
4	Transistor BF194	1No
5	Capacitor 0.1 μ F, 330pf	1 each
6	Resistor- 82k, 18k, 1k, 47K Pot	1 each
7	IFT	1 No

PRINCIPLE

Amplitude Modulation is defined as a process in which the amplitude of the carrier wave $c(t)$ varied linearly with the instantaneous amplitude of the message signal $m(t)$. Modulation is the process by which some characteristics of a carrier signal is varied in accordance with a modulating signal. The base band signal is referred to as the modulating signal and the output of the modulation process is called as the modulation signal.

Amplitude modulation is defined as the process in which is the amplitude of the carrier wave is varied in accordance with the instantaneous amplitude of base band signal. In Amplitude Modulation the amplitude of the carrier wave $c(t)$ is varied linearly with the instantaneous amplitude of the message signal $m(t)$. The standard form the amplitude modulated wave is defined as

$$s(t) = V_c(1 + K_a m(t)) \cos \omega_c t$$

where carrier $V_c \sin \omega_c t$, modulating signal $m(t) = V_m \sin \omega_m t$

Modulation index is defined as

$$m = \frac{E_{max} - E_{min}}{E_{max} + E_{min}} = \frac{V_m}{V_c}$$

Amplitude Modulated signal

$$s(t) = V_c \sin \omega_c t + \frac{mV_c}{2} \cos(\omega_c - \omega_m)t - \frac{mV_c}{2} \cos(\omega_c + \omega_m)t$$



<https://www.gptcthirurangadi.in>

PROCEDURE



1. Set up the circuit after verifying the condition of components.
2. Feed AF modulating signal (say, $f_m = 1\text{kHz}$ and $E_m = 5\text{mV}$) using a function generator.
3. Adjust amplitude and frequencies of the AF and carrier signals and observe amplitude modulated waveform on the CRO.
4. Adjust IFT and note down E_{max} and E_{min} of the AM signal and calculate modulation index according to the formula,

$$m = \frac{E_{max} - E_{min}}{E_{max} + E_{min}}$$

Here E_{max} is the maximum of the positive envelope of the carrier and E_{min} is the minimum of the positive envelope of the carrier.

5. Plot the waveforms on a graph sheet.

RESULT

INFERENCE



CIRCUIT DIAGRAM

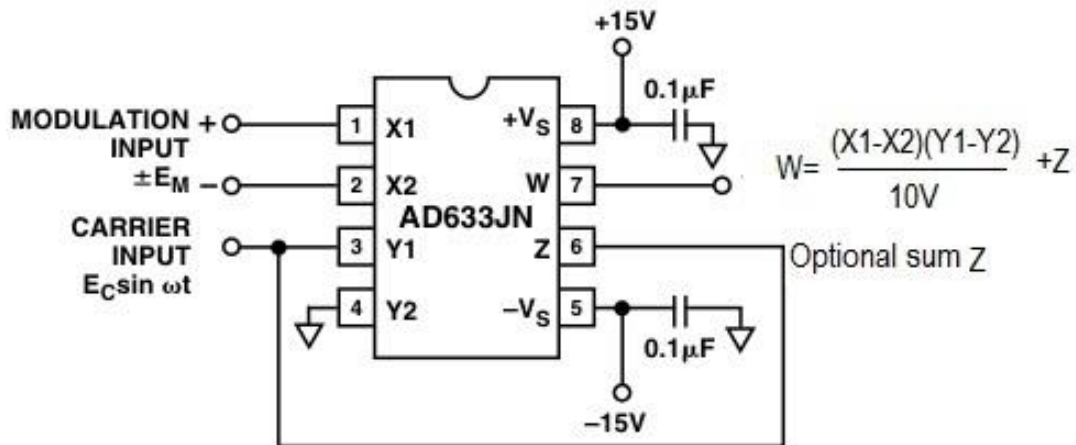

Capacitors – 0.1 μF each

Internal Diagram of IC633

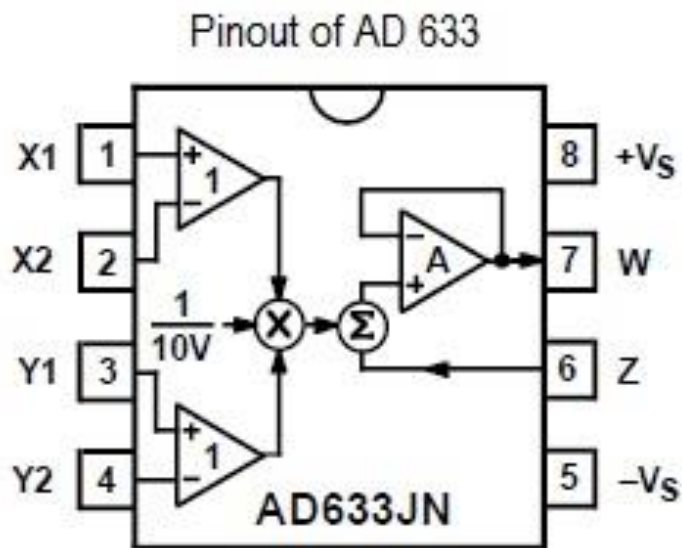



EXPERIMENT No: 4

AM GENERATOR USING IC AD633

AIM

To set up an AM generator using IC AD633.

OBJECTIVES

To use IC AD633 as an AM Generator.

EQUIPMENTS/COMPONENTS

Sl No	Name & Specification	Quantity required
1	CRO/DSO	1No
2	Function Generator	2 No s
3	Dual Power supply +/-15V	1 No
4	IC AD633	1No
5	Capacitor 0.1 μ F	2 Nos

PRINCIPLE

The AD633 is a functionally complete, four-quadrant, analogue multiplier. It includes high impedance, differential X and Y inputs and a high impedance summing input (Z). The low impedance output voltage is a nominal 10 V full scale provided by a buried Zener. The AD633 is laser calibrated to a guaranteed total accuracy of 2% of full scale. Nonlinearity for the Y-input is typically less than 0.1% and noise referred to the output is typically less than 100 mV rms in a 10 Hz to 10 kHz bandwidth. A 1 MHz bandwidth, 20 V/ms slew rate, and the ability to drive capacitive loads make the AD633 useful in a wide variety of applications where simplicity and cost are key concerns.

The Z-input provides access to the output buffer amplifier, enabling the user to sum the outputs of two or more multipliers, increase the multiplier gain, convert the output voltage to a current, and configure a variety of applications.

The AD633 is well suited for such applications as modulation and demodulation, automatic gain control, power measurement, voltage controlled amplifiers, and frequency doublers.

The AD633 can be used as a linear amplitude modulator with no external components. The carrier and modulation inputs to the AD633 are multiplied to produce a double-sideband signal. The carrier signal is fed forward to the AD633's Z input where it is summed with the double sideband signal to produce a double-sideband with carrier output.



OBSERVATION

Sl..No	Am(volts)	V_{\max}	V_{\min}	m	%m

GRAPH



PROCEDURE

1. Check all components, equipments and probes.
2. Set up the connections as per the diagram.
3. Feed $5V_{pp}/30\text{KHz}$ sine wave as carrier and $10v_{pp}/1\text{KHz}$ sine wave as modulating signal.
4. Observe the output waveform and calculate modulation index.

RESULT

INFERENCE



CIRCUIT DIAGRAM:

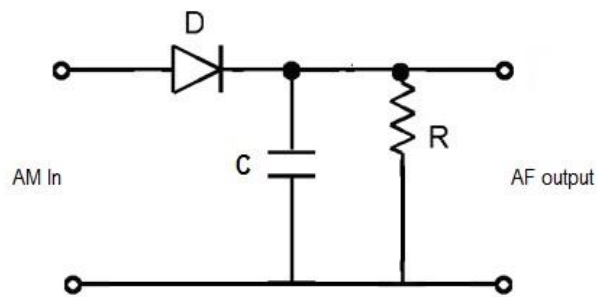

Diode – OA79, $C=1\mu\text{F}$ $R=330\Omega$

GRAPH

EXPERIMENT No: 5



AM DEMODULATOR

AIM

To set up an AM demodulator.

OBJECTIVES

To study the concept of AM Demodulation.

EQUIPMENTS/COMPONENTS

Sl No	Name & Specification	Quantity required
1	CRO/ DSO	1 No
2	AM Generator	1 No
3	Diode OA 79	1 No
4	Capacitor $1\mu\text{F}$	1 No
5	Resistor 300Ω	1 No

PRINCIPLE

The demodulation circuit is used to recover the message signal from the incoming AM wave at the receiver. An envelope detector is a simple and yet highly effective device that is well suited for the demodulation of AM wave, for which the percentage modulation is less than 100%. Ideally, an envelope detector produces an output signal that follows the envelop of the input signal wave form exactly hence, the name. Some version of this circuit is used in almost all commercial AM radio receivers. A diode detector followed by a filter circuit can perform demodulation.

PROCEDURE

1. Check all components, equipments and probes.
2. Set up the connections as per the diagram.
3. Feed the AM wave to the demodulator circuit and observe the output.
4. Note down frequency and amplitude of the demodulated output waveform.
5. Draw the demodulated wave form, $m=1$.
6. Change modulation index of AM signal and verify waveform.

RESULT

INFERENCE



.CIRCUIT DIAGRAM

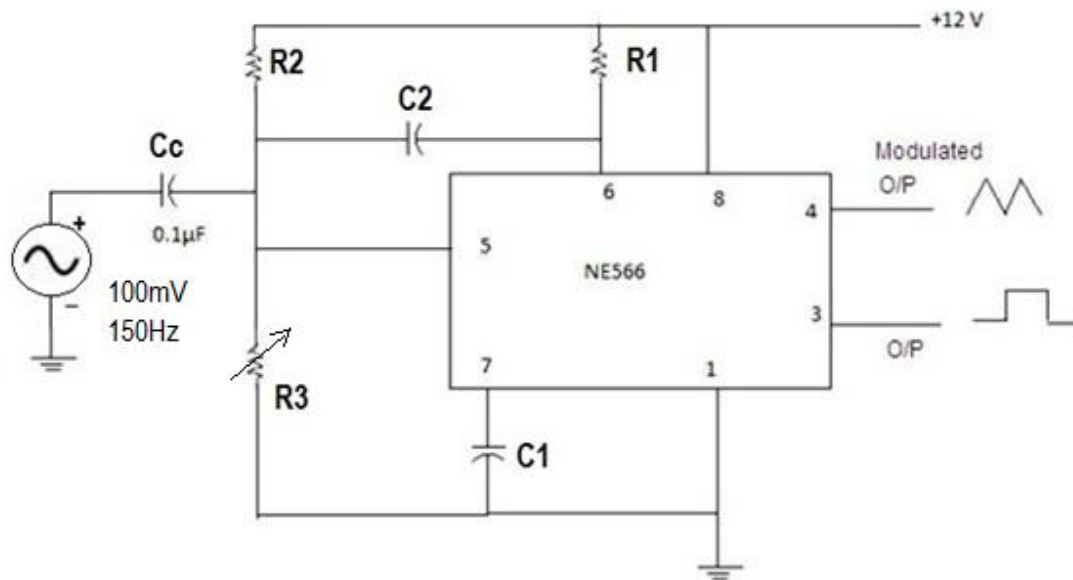

$R_1=6.8K$, $R_2=10K$, $R_3=47K$, $C_c=0.1\mu F$, $C_1=0.01\mu F$, $C_2=0.001\mu F$

Internal Diagram of IC566

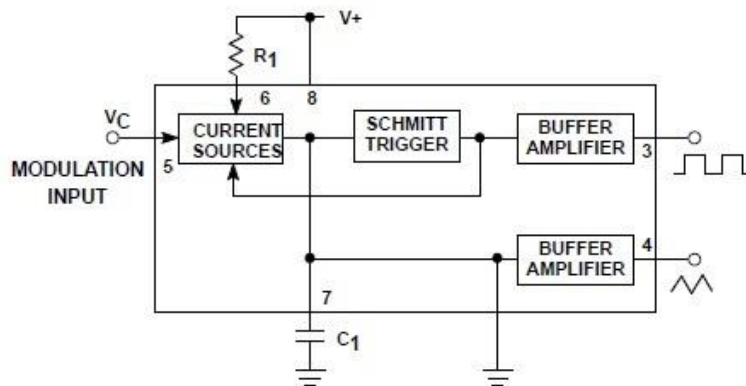

GRAPH

EXPERIMENT No: 6



FM MODULATOR

AIM

To set up FM modulator using IC 566.

OBJECTIVES

Study about FM Modulator using IC 566.

EQUIPMENTS

Sl. No	Name & Specification	Quantity required
1	CRO/DSO	1 No
2	Function Generator	2 No s
3	Regulated DC Power supply 0-12v	1No
4	IC566	1No
5	Capacitors 0.1 μ F, 0.001 μ F, 0.01 μ F	1 Each
6	Resistors 10K, 6.8K, 47K	1 Each

PRINCIPLE

Frequency modulation is a process of changing the frequency of a carrier wave in accordance with a base band signal. The main advantage of this modulation is that it can provide better discrimination against noise .A VCO is a circuit that provides an oscillating signal whose frequency can be adjusted over a control by DC voltage. VCO can generate both square and triangular wave signal whose frequency is set by an external capacitor and resistor and then varied by an applied DC voltage. IC 566 contains a current source to charge and discharge an external capacitor C1 at a rate set by an external resistor R1 and a modulating DC output voltage. The Schmitt trigger circuit present in the IC is used to switch the current source between charge and discharge capacitor and triangular voltage developed across the capacitor and the square wave from the Schmitt trigger are provide as the output of the buffer amplifier. The R2 and R3 combination is a voltage divider, the voltage VC must be in the range $\frac{3}{4} VCC < VC < VCC$. The modulating voltage must be less than $\frac{3}{4}VCC$ the frequency f_c can be calculated using the formula $f_o = \frac{2(VCC-Vc)}{R1 C1 VCC}$ For a fixed value of VC and a constant C1 the frequency can be varied at 10:1 similarly for a constant R1C1 product value the frequency modulation can be done at 10:1 ratio.

PROCEDURE

- 1.Check all components, equipments and probes.
2. Without giving modulating signal observe the carrier signal at pin no.3.
Measure amplitude and frequency of the carrier signal.



<https://www.gptcthirurangadi.in>

3. Apply the sinusoidal modulating signal of frequency 150Hz and amplitude 100mV at pin no.5.



4. Observe output waveform.

RESULT

INFERENCE

.

CIRCUIT DIAGRAM

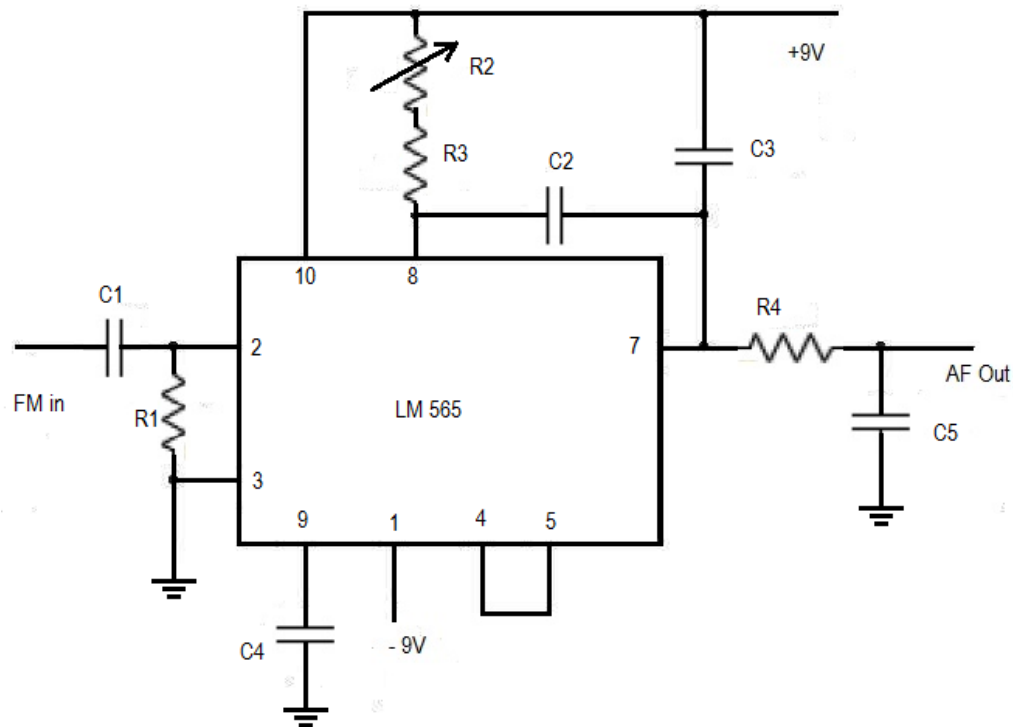

$C_1=0.1\mu\text{F}$, $R_1=620\Omega$, $R_2=10\text{K}$, $R_3=4.7\text{K}$, $C_2=.001\mu\text{F}$, $R_4=1\text{K}$, $C_3=.1\mu\text{F}$ $C_4=0.001\mu\text{F}$

Internal Diagram of IC565

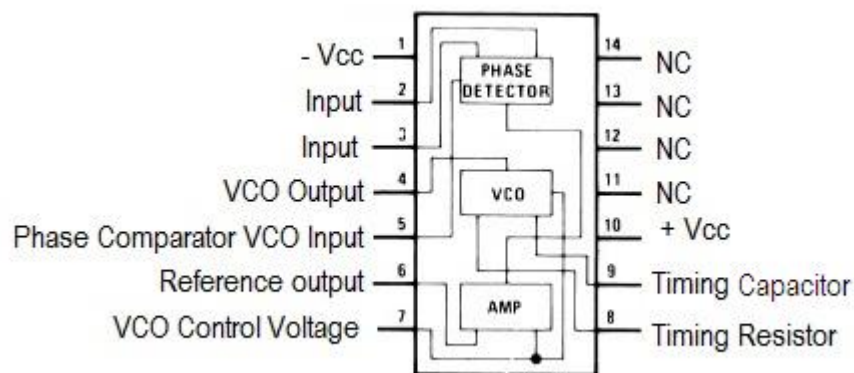

GRAPH

EXPERIMENT No :7



FM DEMODULATOR USING IC565

AIM

To set up FM de modulator using IC 565.

OBJECTIVES

Study about FM Demodulation using IC 565.

EQUIPMENTS/COMPONENTS

Sl No	Name & Specification	Quantity required
1	CRO/ DSO	1 No
2	FM Generator	1 No
3	Regulated DC Power supply	1 No
4	IC 565 PLL	1 No
5	Capacitors 0.1 μ F,0.001 μ F	3,2 Nos
6	Resistors 620 Ω ,10Kpot, 4.7K, 1K	1 each

PRINCIPLE

The LM565 and LM565C are general purpose phase locked loops containing a stable, highly linear voltage controlled oscillator for low distortion FM demodulation, and a double balanced phase detector with good carrier suppression. The VCO frequency is set with an external resistor and capacitor, and a tuning range of 10:1 can be obtained with the same capacitor. The characteristics of the closed loop system - bandwidth, response speed, capture and pull in range - may be adjusted over a wide range with an external resistor and capacitor. The loop may be broken between the VCO and the phase detector for insertion of a digital frequency divider to obtain frequency multiplication.

PROCEDURE

1. Set up the circuit after verifying the condition of components.
2. Feed FM signal using an FM generator.
3. Adjust amplitude of the FM signal and observe modulating signal on the CRO.

RESULT

INFERENCE



CIRCUIT DIAGRAM

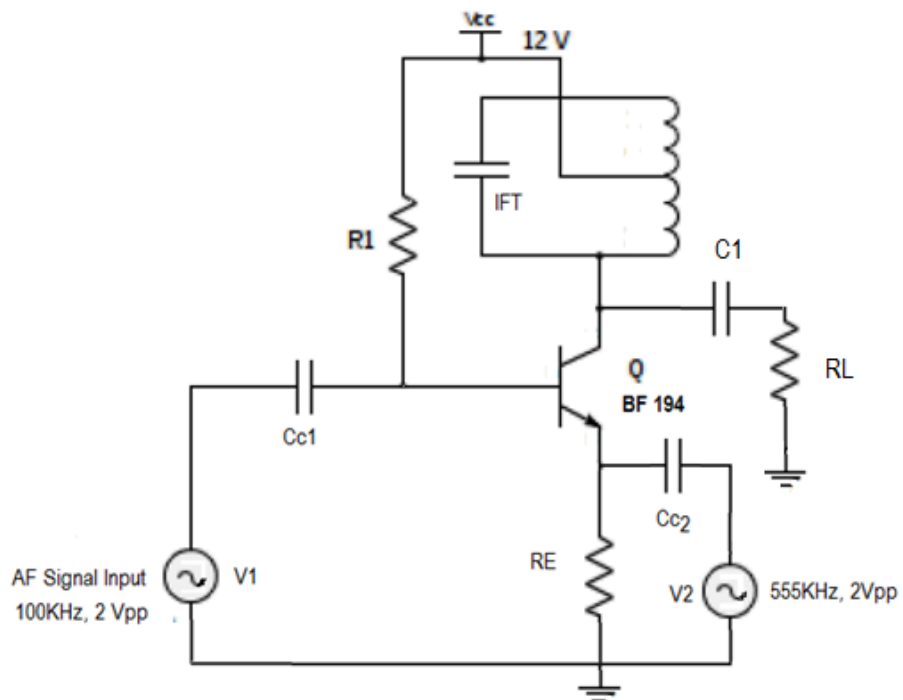

$R_1=680K$, $R_E=1.2K$, $C_{C1}=0.1\mu F$, $C_{C2}=0.1\mu F$, $C_1=10\mu F$, $R_L=1K$

EXPERIMENT No: 8



MIXER STAGE USING DISCRETE COMPONENTS

AIM

To set up mixer stage using discrete components.

OBJECTIVES

To study about the Mixer stage using discrete components.

EQUIPMENTS/COMPONENTS

Sl No	Name & Specification	Quantity required
1	CRO/ DSO	1 No
2	Function Generator	1 No
3	Regulated DC Power supply	1 No
4	Transistor BF194	1 No
5	IFT	1 No
6	Capacitors 0.1 μ F, 10 μ F	2, 1 No
7	Resistors 680K, 1.2K, 1K	1 Each

PRINCIPLE

A mixer or frequency mixer is a nonlinear electrical circuit that creates new frequencies from two signals applied to it. In its most common application, two signals at frequencies f_1 and f_2 are applied to a mixer, and it produces new signals at the sum $f_1 + f_2$ and difference $f_1 - f_2$ of the original frequencies. Other frequency components (like $f_1 \pm 2f$) may also be produced in a practical frequency mixer. The most important application of mixers is in superhetrodyne receivers where the very high carrier frequency is down converted to an intermediate frequency. This is done by mixing the carrier frequency with a locally generated oscillator frequency to get an output frequency which is the difference between local oscillator frequency and incoming signal frequency, ie the intermediate frequency. In widely used AM receivers the local oscillator frequency is so chosen with respect to carrier frequency such that their difference is a constant intermediate frequency of 455 kHz.

$f_{IF} = f_{oscillator} - f_{carrier} = 455 \text{ kHz}$. The mixer output which contains all image frequencies of $f_1 \pm nf_2$ is filtered to obtain the required difference frequency $f_1 - f_2$.

PROCEDURE

1. Set up the circuit after verifying the condition of components.
2. Apply sine wave 2Vpp/100kHz and 2Vpp/555 kHz using a function generator. (555 kHz-100kHz=455kHz).
3. Verify the waveform on the CRO.

RESULT

INFERENCE

CIRCUIT DIAGRAM:

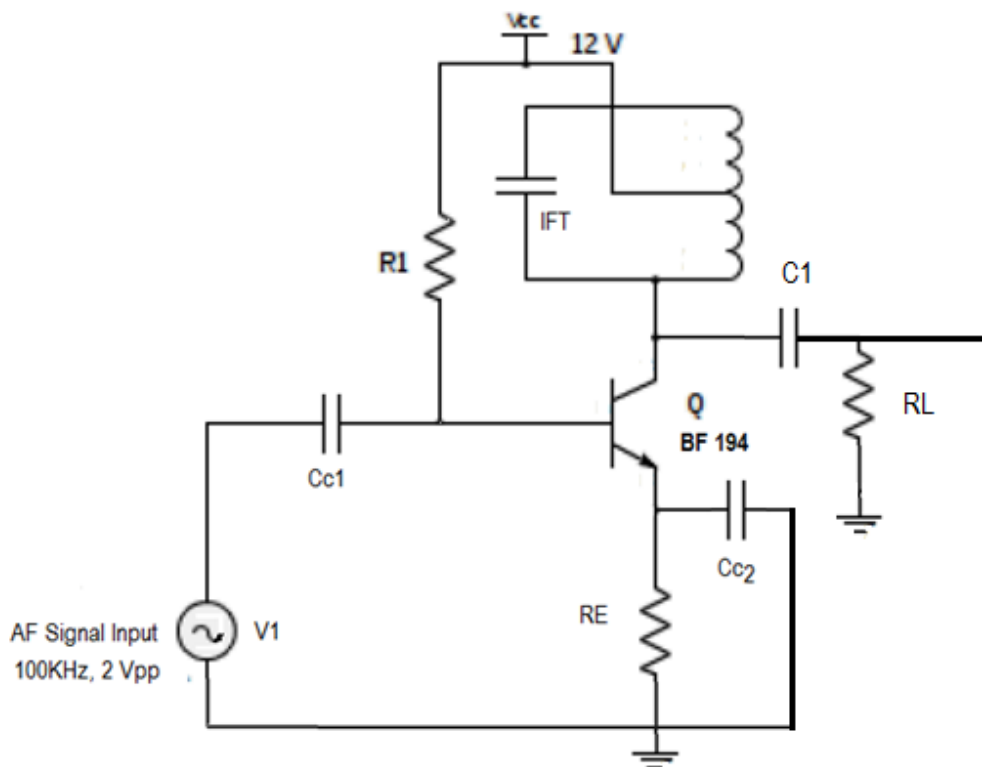

$R_1=680K$, $R_E=1.2K$, $C_{C1}=0.1\mu F$, $C_{C2}=0.1\mu F$, $C_1=10\mu F$, $R_L=1K$

OBSERVATION:

Sl.No	Frequency(KHz)	Vout(V)	Gain=(Vout/Vin)	Gain in dB=20logAv

GRAPH

EXPERIMENT No : 9



IF TUNED AMPLIFIER

AIM

To set up an IF tuned amplifier.

OBJECTIVES

To study about IF Tuned Amplifiers.

EQUIPMENTS/COMPONENTS

Sl No	Name & Specification	Quantity required
1	CRO/ DSO	1 No
2	Function Generator	1 No
3	Regulated DC Power supply	1 No
4	Transistor BF194	1 No
5	IFT	1 No
6	Capacitors 0.1 μ F, 0.1 μ F	1 Each
7	Resistors 680K, 1.2K, 10 μ F, 1K	1 Each

PRINCIPLE

Intermediate frequency amplifiers are tuned voltage amplifiers used to amplify a particular frequency. Its primary function is to amplify only the tuned frequency with maximum gain and reject all other frequencies above and below this frequency. These types of amplifiers are widely used in intermediate frequency amplifiers in AM super heterodyne receivers, where intermediate frequency is usually 455 kHz. In tuned voltage amplifier the collector resistance is replaced by a tuned load upon which the gain is dependent. For a parallel resonating circuit consisting of a capacitor, C and an inductor, L the impedance Z_o is maximum at resonant frequency, $f_o = 1/2\pi \sqrt{LC}$. So an amplifier with tuned load will have maximum gain at resonant frequency. In practical tuned amplifier circuits, an intermediate frequency transformer (IFT) is used as tuned load. IFT is tuned to standard 455 kHz audio frequency. The quality factor of the circuit is given by $Q = f_o/\text{Bandwidth}$.

PROCEDURE

1. Check all components, equipments and probes.
2. Set up the connections as per the diagram.
3. Feed the sine wave of 1Vpp/350kHz the circuit and observe the output.
4. Vary the input frequency up to 550 kHz with uniform increment of 25 kHz.
5. Find the Gain and draw the graph. Mark 3dB points on the graph (f_1, f_2).
6. Calculate the bandwidth $BW=f_1-f_2$ and Q factor, $Q=f_o/BW$
(f_o =resonant frequency, BW =bandwidth).



<https://www.gptcthirurangadi.in>

RESULT



INFERENCE

CIRCUIT DIAGRAM



Pre-emphasis

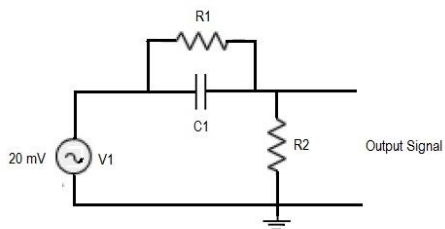

De-emphasis

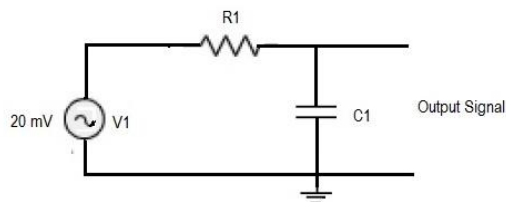

$R_1=4.7K$, $C_1=0.01\mu F$, $R_2=1K$

OBSERVATION

Table.1 Pre-emphasis

Sl.No	Frequency(KHz)	Vout(mV)	Gain=(Vout/Vin)	Gain in dB=20logAv

Table.2 De-emphasis

Sl.No	Frequency(KHz)	Vout(mV)	Gain=(Vout/Vin)	Gain in dB=20logAv

GRAPH:



PRE-EMPHASIS AND DE-EMPHASIS CIRCUITS

AIM

To set up pre-emphasis and de-emphasis circuits.

OBJECTIVES

To study about Pre-emphasis and De-emphasis circuits.

EQUIPMENTS/COMPONENTS:

SI No	Name & Specification	Quantity required
1	CRO/ DSO	1 No
2	Function Generator	1 No
3	Capacitors $0.01\mu\text{F}$	1 No
4	Resistors 4.7K, 1K	1 Each

PRINCIPLE

The noise has an effect on the higher modulating frequencies than on the lower ones. Thus, if the higher frequencies were artificially boosted at the transmitter and correspondingly cut at the receiver, an improvement in noise immunity could be expected, thereby increasing the signal to noise ratio (SNR ratio). This boosting of the higher modulating frequencies at the transmitter is known as pre-emphasis and the compensation at the receiver is called de-emphasis.

PROCEDURE

1. Check all components, equipments and probes.
2. Set up the connections as per the diagram.
3. Apply the sinusoidal signal of amplitude 20mV as input signal to pre-emphasis circuit.
4. Then by increasing the input signal frequency from 500Hz to 20KHz, observe the output voltage (v_o) and calculate gain ($20 \log (v_o/v_i)$).
5. Plot the graph between gain Vs frequency.
6. Repeat above steps 3 and 4 for de-emphasis circuit by applying the sinusoidal signal of 5V as input signal.

RESULT

INFERENCE

CIRCUIT DIAGRAM



Modulator

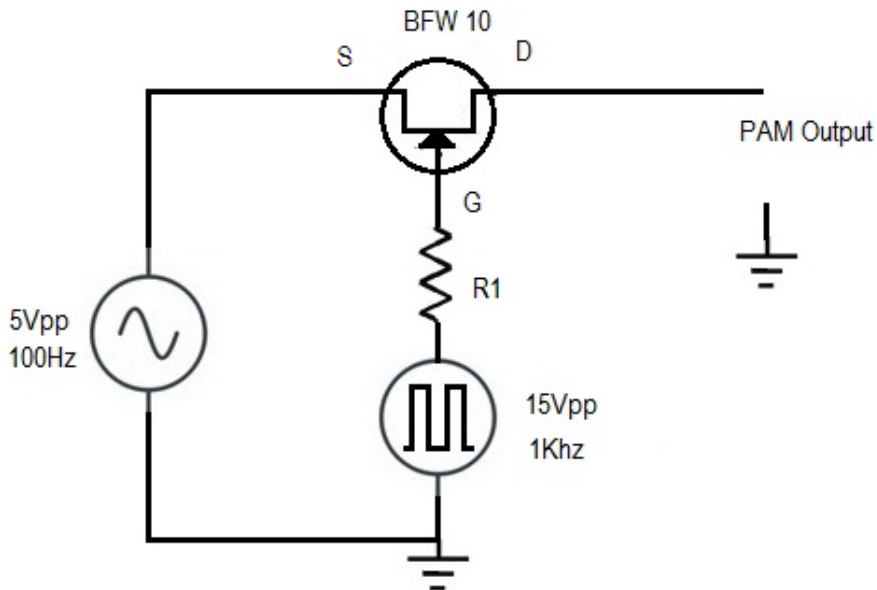

$R1=56\Omega$

Demodulator

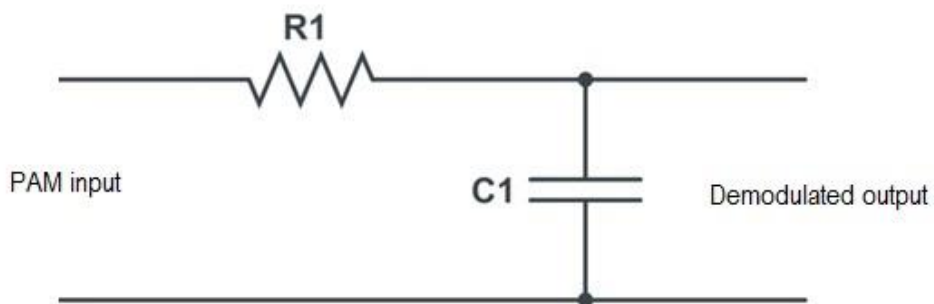

$R_1=1K, C_1=1\mu F$

GRAPH

EXPERIMENT No:11



PULSE AMPLITUDE MODULATOR AND DEMODULATOR

AIM

To set up pulse amplitude modulator and demodulator

OBJECTIVES

Study about the pulse amplitude modulator and demodulator.

EQUIPMENTS/COMPONENTS

Sl No	Name & Specification	Quantity required
1	CRO/ DSO	1 No
2	Function Generator	2 No
3	FET BFW10	1 No
4	Resistor 56Ω	1 No

PRINCIPLE

Pulse modulation is used to transmit analogue information. In this system continuous wave forms are sampled at regular intervals. Information regarding the signal is transmitted only at the sampling times together with syncing signals. At the receiving end, the original waveforms may be reconstituted from the information regarding the samples. The pulse amplitude modulation is the simplest form of the pulse modulation. PAM is a pulse modulation system in which the signal is sampled at regular intervals, and each sample is made proportional to the amplitude of the signal at the instant of sampling. The pulses are then sent by either wire or cables are used to modulated carrier.

The two types of PAM are i) Double polarity PAM, and ii) the single polarity PAM, in which a fixed dc level is added to the signal to ensure that the pulses are always positive. Instantaneous PAM sampling occurs if the pulses used in the modulator are infinitely short. Natural PAM sampling occurs when finite-width pulses are used in the modulator, but the tops of the pulses are forced to follow the modulating waveform. Flat-topped sampling is a system quite often used because of the ease of generating the modulated wave. PAM signals are very rarely used for transmission purposes directly. The reason for this lies in the fact that the modulating information is contained in the amplitude factor of the pulses, which can be easily distorted during transmission by noise, crosstalk, other forms of distortion. They are used frequently as an intermediate step in other pulse modulating methods, especially where time-division multiplexing is used.

PROCEDURE

1. Check all components, equipments and probes.
2. Set up the connections as per the diagram.
3. Set the modulating frequency to 5V/ 100Hz and sampling frequency to 15V/1kHz



<https://www.gptcthirurangadi.in>

4. Observe the output on CRO. i.e. PAM wave.
5. Measure the levels of the output waveform.



6. Feed the modulated wave to the low pass filter.
7. The output observed on CRO will be the demodulated wave.
8. Note down the amplitude and time period of the demodulated wave.
9. Plot the wave forms on graph.

RESULT

INFERENCE

CIRCUIT DIAGRAM

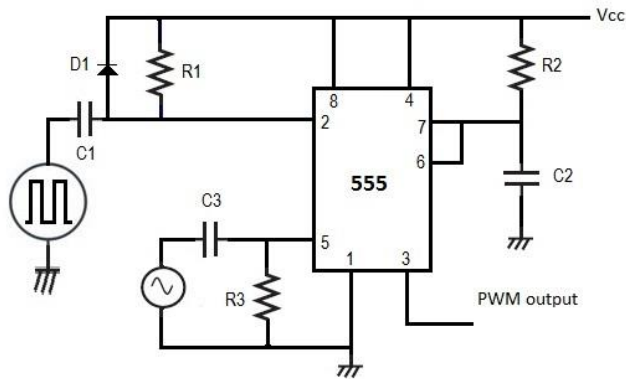

$R_1=1.2K$, $R_2=4.7K$, $R_3=10K$, $C_1=0.001\mu F$, $C_2=0.1\mu F$, $C_3=10\mu F$

Internal Diagram of IC555

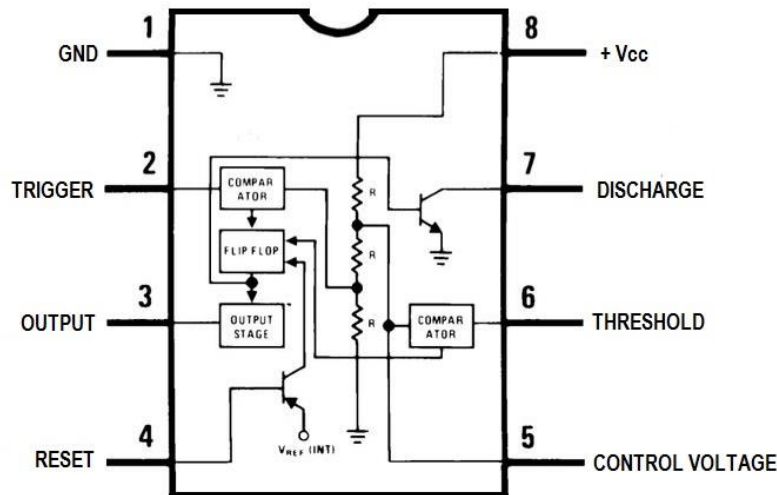

GRAPH



EXPERIMENT No:12

PULSE WIDTH MODULATOR USING IC555

AIM

To set up pulse width modulator using IC 555.

OBJECTIVES

To study about the Pulse Width Modulator using IC555.

EQUIPMENTS/COMPONENTS

Sl No	Name & Specification	Quantity required
1	CRO/ DSO	1 No
2	Function Generator	2 Nos
3	Regulated DC Power supply	1 No
4	IC 555	1 No
5	Diode IN4007	1 No
6	Capacitors 0.001 μ F, 10 μ F, 0.1 μ F	1 Each
7	Resistors 1.2K, 10K, 4.7K	1 Each

PRINCIPLE

Pulse Time Modulation is also known as Pulse Width Modulation or Pulse Length Modulation. In PWM, the samples of the message signal are used to vary the duration of the individual pulses. Width may be varied by varying the time of occurrence of leading edge, the trailing edge or both edges of the pulse in accordance with modulating wave. It is also called Pulse Duration Modulation.

PROCEDURE

1. Check all components, equipments and probes.
2. Set up the connections as per the diagram.
3. Apply a trigger signal (Pulse wave) of 5Vpp/ 2 kHz.
4. Observe the sample signal at the pin3.
5. Apply the ac signal at the pin 5 and vary the amplitude.
6. Note that the control voltage is varied output pulse width is also varied.
7. Observe the pulse width increases during positive slope condition and decreases under negative slope condition. Pulse width will be maximum at the positive peak and minimum at the negative peak of sinusoidal waveform. Record the observations.

RESULT

INFERENCE

CIRCUIT DIAGRAM

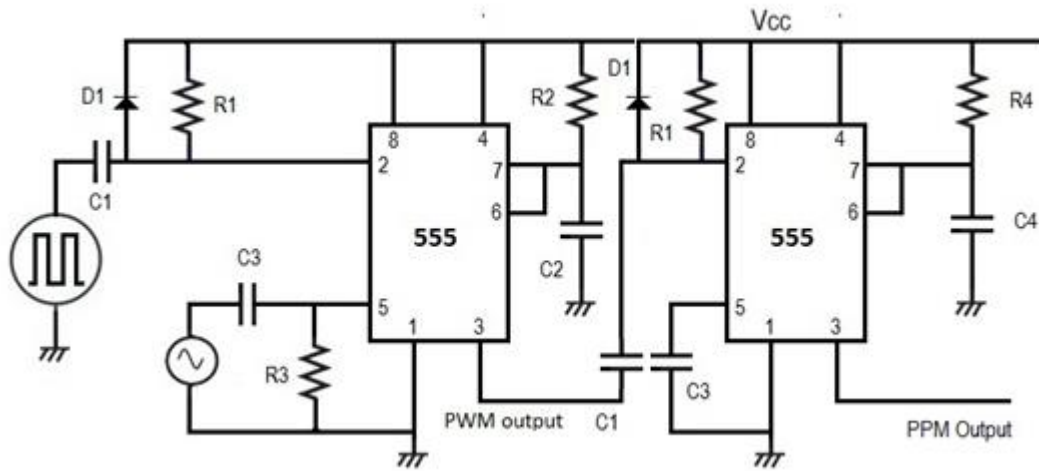

$C1=0.001\mu F$, $R1=1.2K$, $R2=4.7K$, $R3=10K$, $R4=4.7K$ $C2=0.1\mu F$, $C3=0.001\mu F$, $C4=0.01\mu F$

GRAPH

EXPERIMENT No:13



PULSE POSITION MODULATOR USING IC555

AIM

To set up pulse position modulator using 555.

OBJECTIVES

To study about Pulse Position Modulator using IC555.

EQUIPMENTS/COMPONENTS

Sl No	Name & Specification	Quantity required
1	CRO/ DSO	1 No
2	Function Generator	1 No
3	Regulated DC Power supply	1 No
4	IC 555	2 No
5	Diode IN 4001	1 No
6	Capacitors 0.001 μ F, 0.01 μ F, 10 μ F, 0.01 μ F	1 Each
7	Resistors 1.2K, 4.7K, 10K	2,2,1 No

PRINCIPLE

In Pulse Position Modulation, both the pulse amplitude and pulse duration are held constant but the position of the pulse is varied in proportional to the sampled values of the message signal. Pulse time modulation is a class of signalling techniques that encodes the sample values of an analogue signal on to the time axis of a digital signal and it is analogous to angle modulation techniques. The two main types of PTM are PWM and PPM. In PPM the analogue sample value determines the position of a narrow pulse relative to the clocking time. In PPM rise time of pulse decides the channel bandwidth. It has low noise interference.

PROCEDURE

1. Check all components, equipments and probes.
2. Set up the connections as per the diagram.
3. Observe the sample output at pin 3 and observe the position of the pulses on CRO and adjust the amplitude by slightly increasing the power supply. Also observe the frequency of pulse output.
3. Apply the modulating signal, sinusoidal signal of 2Vpp to the control pin 5.
4. Now by varying the amplitude of the modulating signal, note down the position of the pulses.
5. Observe the output on CRO and plot the waveform.

RESULT

INFERENCE

CIRCUIT DIAGRAM

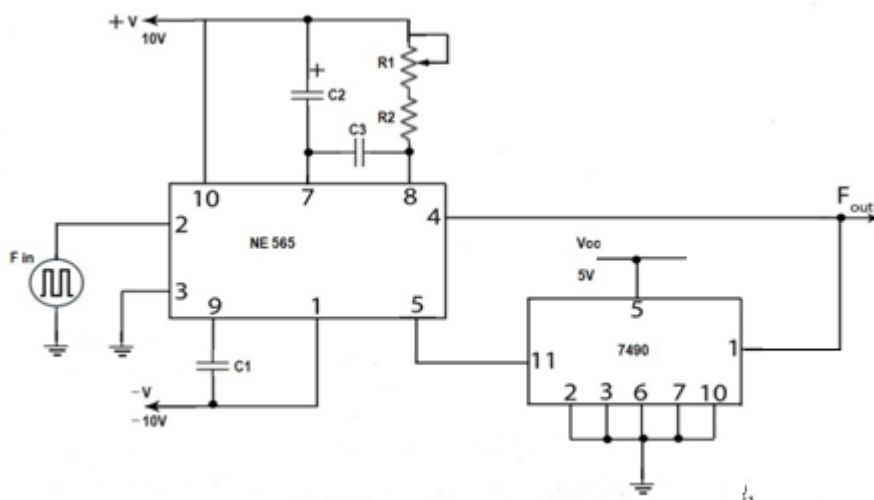

$C1=0.01\mu\text{F}$, $C2=10\mu\text{F}$, $C3=0.01\mu\text{F}$, $R1=10\text{K Pot}$, $R2=4.7\text{K}$,

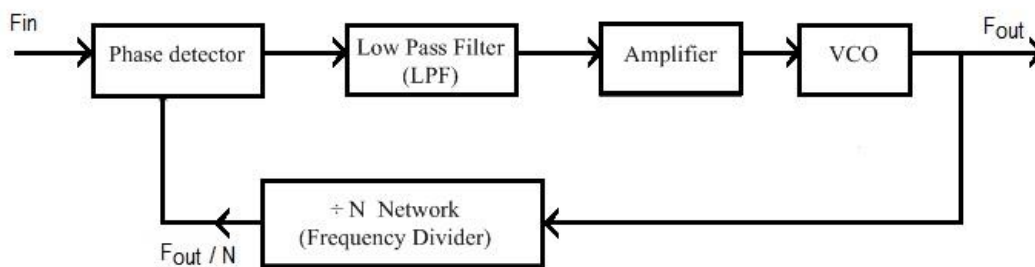

GRAPH

EXPERIMENT No:14



FREQUENCY MULTIPLIER USING IC565

AIM

To set up frequency multiplier using IC 565.

OBJECTIVES

To study about the Frequency multiplier circuit using IC565.

EQUIPMENTS/COMPONENTS:

Sl No	Name & Specification	Quantity required
1	CRO/ DSO	1 No
2	Function Generator	1 No
3	Regulated DC Power supply	1 No
4	IC565	1 No
5	IC7490	1 No
6	Capacitors 10 μ F, 0.01 μ F	1,2 Nos
7	Resistors 10K pot, 4.7K	1 Each

PRINCIPLE

The block diagram of a frequency multiplier (or synthesizer) is shown in figure. In this circuit, a frequency divider is inserted between the output of the VCO and the phase comparator (PC) so that the loop signal to the PC is at frequency f_{OUT} while the output of VCO is $N f_{OUT}$. This output is a multiple of the input frequency as long as the loop is in lock. The desired amount of multiplication can be obtained by selecting a proper divide- by N network where N is an integer. Figure shows this function performed by a 7490 configured as a divide-by-5 circuit.

In this case the input V_{in} at frequency f_{in} is compared with the output frequency f_{OUT} at pin 5. An output at $N f_{OUT}$ ($5 f_{OUT}$ in this case) is connected through an inverter circuit to give an input at pin 14 of the 7490, which varies between 0 and + 5 V. Using the output at pin 9, which is one-fourth of that at the input to the 7490, the signal at pin 4 of the PLL is five times the input frequency as long as the loop remains in lock.

Since the VCO can be adjusted over a limited range from its centre frequency, it may become necessary to change the VCO frequency whenever the divider value is changed.

For verification of the circuit operation, one must determine the input frequency range and then adjust the free running f_{OUT} of the VCO by means of R_1 and C_1 so that the output frequency of the 7490 divider is midway within the predetermined input frequency range. The output of VCO should now be equal to $5 f_{in}$.



<https://www.gptcthirurangadi.in>

PROCEDURE



1. Check all components, equipments and probes.
2. Set up the connections as per the diagram.
3. Verify the working of 565 and counter separately.
4. Apply 5V/1kHz positive going pulses at pin no.2 of IC565.
5. Observe the multiplied frequency at pin no.4
6. Plot the input and output waveform.

RESULT

INFERENCE

.

CIRCUIT DIAGRAM

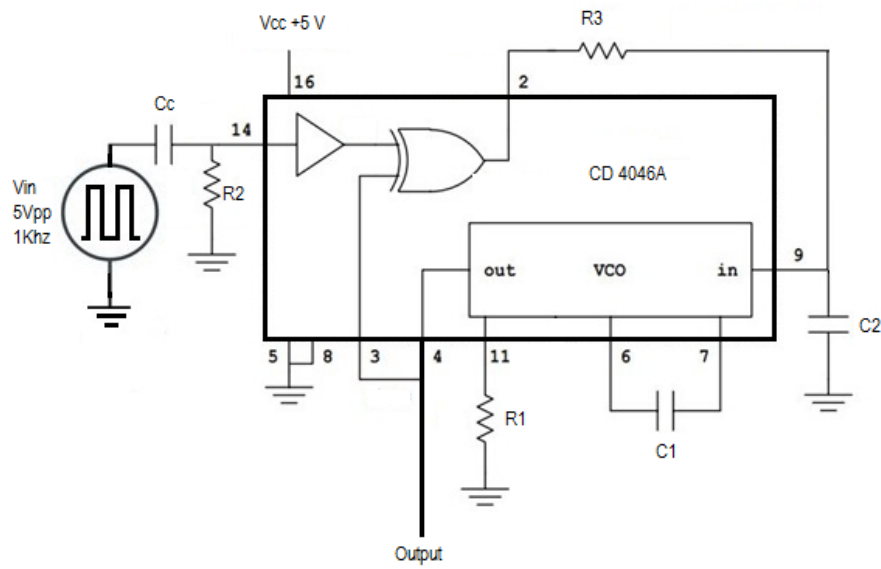

$C_c=10\mu\text{F}$, $R_2=10\text{K}$, $R_3=100\text{K}$, $c_2=0.1\mu\text{F}$, $C_1=560\text{pF}$, $R_1=100\text{K}$

GRAPH:

EXPERIMENT No:15



CMOS PLL4046

AIM

To study the CMOS PLL4046.

OBJECTIVES

To study about the CMOS PLL4046.

EQUIPMENTS/COMPONENTS

SI No	Name & Specification	Quantity required
1	CRO/ DSO	1 No
2	Function Generator	1 No
3	Regulated DC Power supply	1 No
4	Capacitors 560pf, 0.1 μ F, 10 μ F	1 Each
5	Resistors 10K, 100K,	1 Each

PRINCIPLE/THEORY

A phase-locked loop or phase lock loop (PLL) is a control system that tries to generate an output signal whose phase is related to the phase of the input "reference" signal. It is an electronic circuit consisting of a variable frequency oscillator and a phase detector. This circuit compares the phase of the input signal with the phase of the signal derived from its output oscillator and adjusts the frequency of its oscillator to keep the phases matched. The signal from the phase detector is used to control the oscillator in a feedback loop. Frequency is the derivative of phase. Keeping the input and output phase in lock step implies keeping the input and output frequencies in lock step. Consequently, a phase-locked loop can track an input frequency, or it can generate a frequency that is a multiple of the input frequency. The former property is used for demodulation, and the latter property is used for indirect frequency synthesis. Phase-locked loops are widely used in radio, telecommunications, computers and other electronic applications. They may generate stable frequencies, recover a signal from a noisy communication channel, or distribute clock timing pulses in digital logic designs such as microprocessors. Since a single integrated circuit can provide a complete phase-locked-loop building block, the technique is widely used in modern electronic devices, with output frequencies from a fraction of a hertz up to many Giga hertz

When the input frequency is less than f_{L1} , PLL is neither in lock nor in capture, and will be in free running state generating centre frequency f_0 . When input frequency reaches f_{C1} , VCO frequency becomes equal to input frequency, or VCO captures input frequency. If the input frequency increases, VCO frequency follows the input frequency upto the limit of f_{L2} . If input frequency further increases, VCO frequency becomes centre frequency f_0 . If the input frequency reduced, VCO frequency becomes equal to input frequency only at f_{C2} . If input frequency further



decreased, VCO frequency follows input frequency only up to f_{L1} . If input frequency is further decreased, VCO frequency retains original centre frequency f_0 .



The frequency range $f_{L2} - f_{L1}$ can be defined as the lock range, in which PLL keeps lock with input frequency. The frequency range $f_{C2} - f_{C1}$ is called capture range, in which PLL able to capture the input frequency

PROCEDURE

1. Check all components, equipments and probes.
2. Set up the connections as per the diagram.
3. Observe the free running frequency f_0 .
4. Feed a square wave input and vary its frequency from 100Hz to 1 MHz and obtain f_{C1} and f_{L2} .
5. Decrease the frequency from high value to low value and find f_{C2} and f_{L1} .
6. Calculate capture range $f_C (f_{C2}-f_{C1})$ and lock range $f_L (=f_{L2}-f_{L1})$.

RESULT

INFERENCE