



TED (15) – 2005-B

Reg. No.

(REVISION — 2015)

Signature

DIPLOMA EXAMINATION IN ENGINEERING/TECHNOLOGY/
MANAGEMENT/COMMERCIAL PRACTICE — APRIL, 2019

ENGINEERING GRAPHICS

[Time : 3 hours

(Maximum marks : 100)

[Note :— Sketches accompanied.]

PART — A

(Maximum marks : 10)

Marks

I Answer *all* questions in one or two sentences. Each question carries 2 marks.

1. List different types of lines used in engineering drawings.
2. Define first angle projection.
3. Write different types of scales used in engineering practice.
4. State the use of auxiliary views in engineering drawing.
5. List any four options for drawing a circle using Auto CAD.

(5×2 = 10)

PART — B

(Maximum marks : 50)

II Answer any *five* of the following questions. Each question carries 10 marks.

1. Read the dimensioned drawing shown in figure 1. Redraw the figure and dimension it as per BIS.
2. Inscribe an ellipse within a parallelogram of sides 100 mm and 60 mm. The acute angle is 60°.
3. Draw an involute of a square of side 25 mm.
4. Draw the projections of the following points on a common reference line.
 - (a) Point P is in HP and 30mm in front of VP.
 - (b) Point Q is in VP and 35mm below HP.
 - (c) Point R is in both HP and VP.
 - (d) Point H is in HP and 35mm behind VP.
 - (e) Point T is in VP and 30mm above HP.



Marks

5. A line AB measuring 70 mm has its end A 15 mm in front of VP and 20mm above HP and other end B is 60 mm in front of VP and 50mm above HP. Draw the projections of the line and find the inclinations of the line with both the reference planes of projections.
6. Draw the development of the funnel as shown in the figure 2.
7. A regular pentagonal lamina 40 mm side has its plane vertical and inclined 30° to the VP. Draw the projections when one of its sides is perpendicular to the HP.

(5×10 = 50)

PART — C

(Maximum marks : 40)

(Answer any *two* questions from the following. Each question carries 20 marks.)

- III The pictorial view of a block is shown in figure 3. Draw the following views in first angle projections.
 - (a) Front view in the direction of F.
 - (b) Top view in the direction of T.
 - (c) Left hand side view in the direction of L.
- IV The pictorial view of a machine part is shown in figure 4. Draw the front view and a sectional top view taking section along A-A.
- V The orthographic views of a guide block are shown in figure 5. Draw its cavalier oblique projection and show all the dimension on it.

(2×20 = 40)

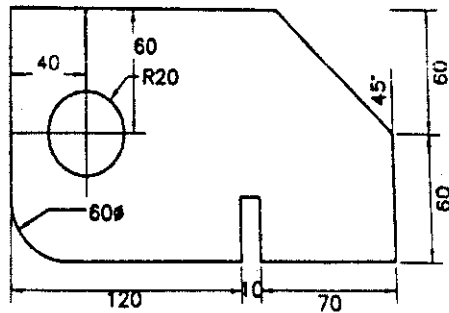

Figure 1.

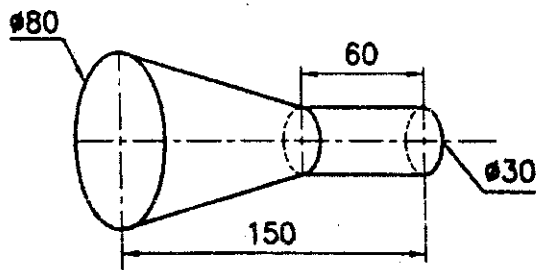

Figure 2.

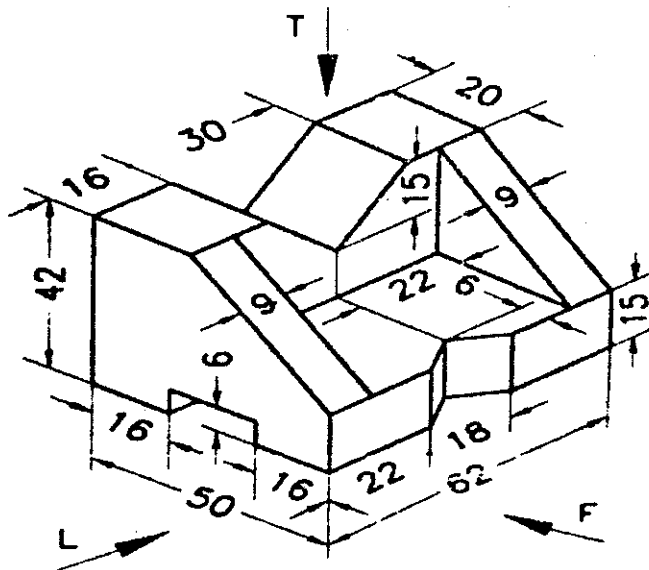

Figure 3.

(ii)

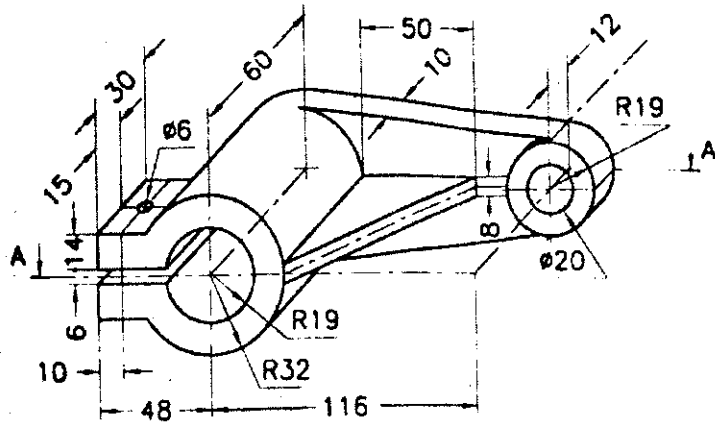

Figure 4.

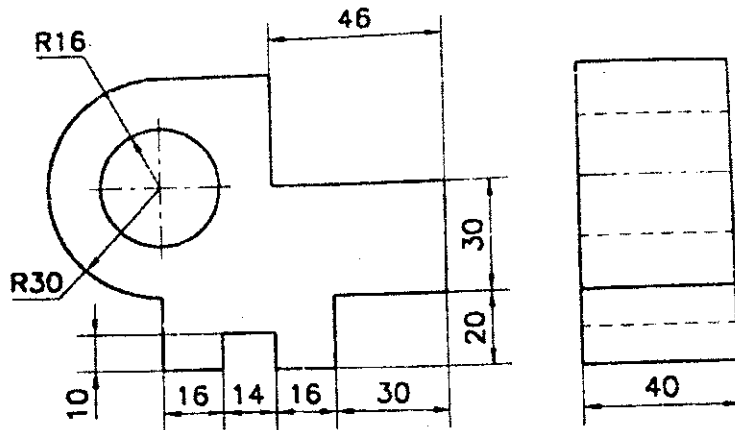

Figure 5.