



TED (15) – 2005

(REVISION – 2015)

Reg. No. ....

Signature .....

DIPLOMA EXAMINATION IN ENGINEERING/TECHNOLOGY/  
MANAGEMENT/COMMERCIAL PRACTICE — OCTOBER, 2017

ENGINEERING GRAPHICS

[Time : 3 hours

(Maximum marks : 100)

- [Note :— 1. Missing data if any suitably assumed.  
2. Sketches to be accompanied.]

PART — A

(Maximum marks : 10)

Marks

- I Answer *all* questions in one or two sentences. Each question carries 2 marks.
1. State the representative fraction.
  2. Define an Involute.
  3. State cavalier oblique projection.
  4. Name any four types of full sectional views of an object.
  5. Name any four options for drawing a *line* in AUTO CAD.

(5×2 = 10)

PART — B

(Maximum marks : 50)

(Answer any *five* of the following questions. Each question carries 10 marks.)

- II Redraw the given figure -1 and put dimension as per BIS.
- III Inscribe a regular heptagon in a circle, if the length of one side of the heptagon is 30mm.
- IV Draw an ellipse having a major axis of 110mm and minor axis of 70mm using concentric circle method.
- V Draw a right hand single start helix of one convolution on a cylinder of base diameter 60mm, height 78mm and pitch 78mm.
- VI The length of elevation of a line GH which is parallel to HP and inclined 30° to VP is 50mm. The end G of the line is 15mm in front of VP and 25mm above HP. Draw the projections of the line and find its true length.



VII Draw the projections of the following points on a common reference line. Keeping the distance between their projectors 30mm apart.

- (a) Point P is 25mm below HP and 40mm in front of VP.
- (b) Point Q is in HP and 35mm behind VP.
- (c) Point R is 25mm in front of VP and in HP.
- (d) Point S is 40mm above HP and 35mm behind VP.
- (e) Point T is 20mm below HP and 35mm behind VP.

VIII Draw the Development of an elbow shown in figure - 2.

(5 × 10 = 50)

PART — C

(Maximum marks : 40)

(Answer any *two* of the following questions. Each question carries 20 marks.)

IX The pictorial view of a block is given in figure - 3. Draw the following orthographic views.

- 1. Front view in the direction of F.
- 2. Top view.
- 3. Left side view.

X Figure - 4 shows the isometric view of a machine block having slope surface. Draw the front view, top view and an auxiliary view of the inclined surface.

XI The orthographic view of a support are shown in figure - 5. Draw its Isometric view.

(2 × 20 = 40)



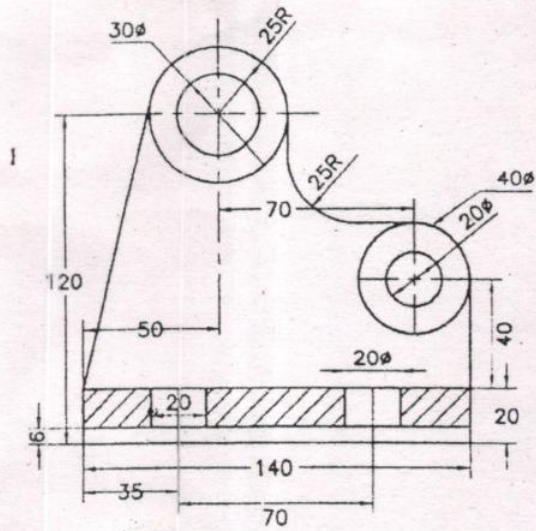

Fig. 1

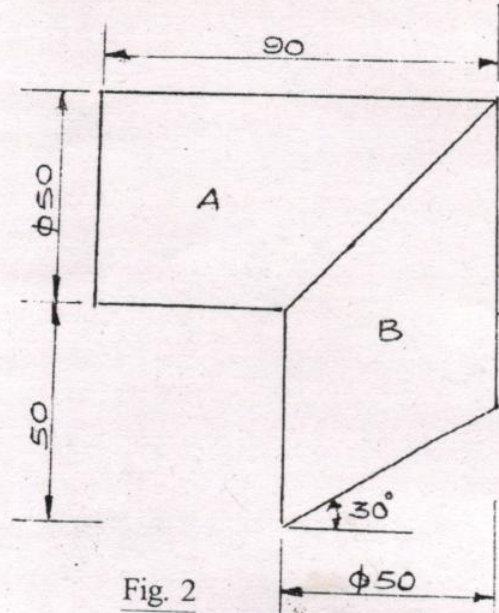

Fig. 2

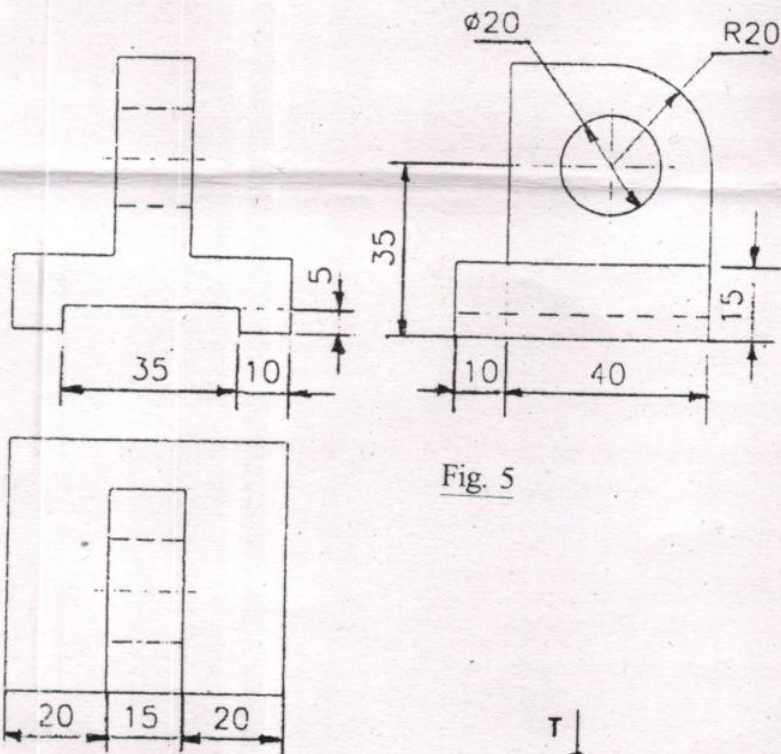

Fig. 5

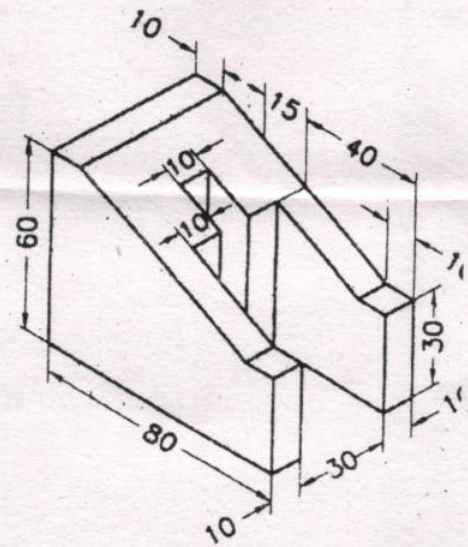

Fig. 4

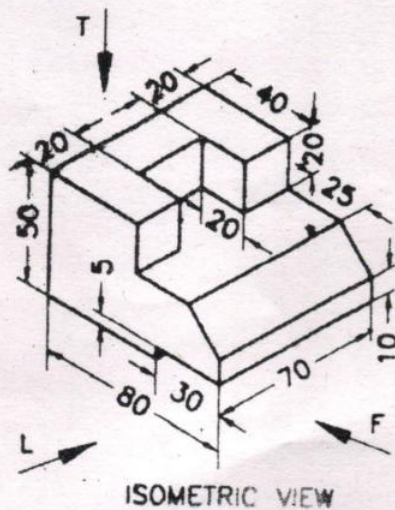

Fig. 3





<https://www.gptcthirurangadi.in>